

nurus



Marla

Design by **Nurus D Lab**

Marla

Marla reinterprets and modernizes hanger with its minimalistic design, well-balanced and sturdy structure, and wide colour options.

Designed to keep the order in all living spaces from executive offices to hotel rooms and work spaces, Marla fits into all areas of use with a modern and stylish look.

Design by Nurus D Lab

Always up-to-date with science and technology, Nurus D Lab designs products that are ahead of their time. Through human-centred observation, prototyping and in respect to trending needs and dreams, the team works diligently. Coming up with meaningful and reflective design solutions only marks the start of the process: From strategy to launch and support, D Lab manages it all. Each detail is attended and tested through at the advanced level.



DIMENSIONS (mm)

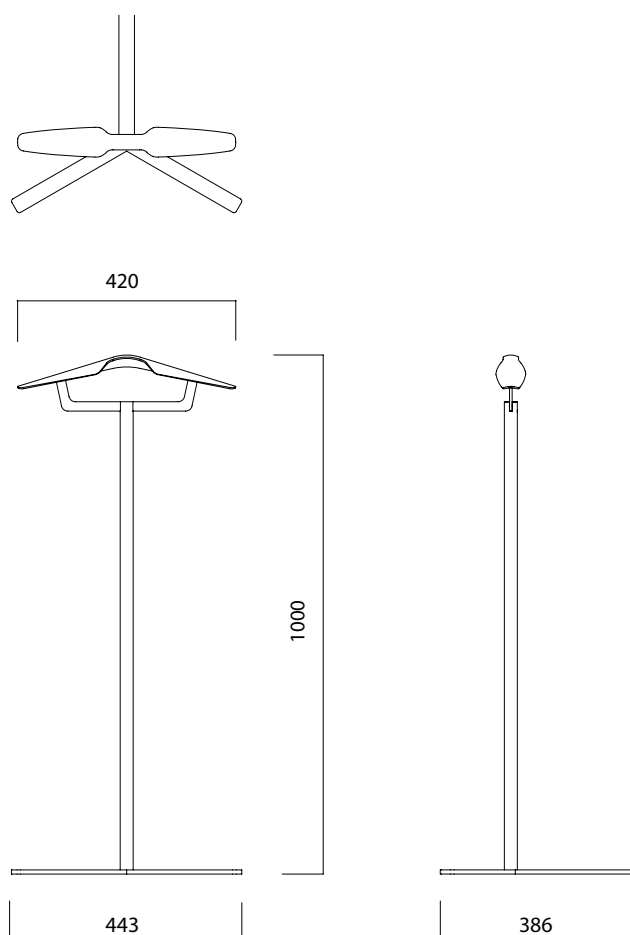

Dimensions defined in millimetres.

Materials

Metal powder-coated body. Accessories are laquered.*

*Please refer to technical document for more information.