

nurus



Ashbury Triangle

Design by **Stefan Brodbeck**

Ashbury Triangle

Like other Ashbury combinations, Ashbury Triangle promotes cooperation and communication while maximizing the work area and putting an end to the cable mess. You may customize your desk with **Nurus Links®** that features a wireless charging unit. The eco-leather desk pad is available in 3 colors.

- Optional **Nurus Links®** with wireless mobile charging support and easy access to USB & electrical connections.
- The eco-leather desk pad available in 3 different colors.

nurus links®

Nurus Links® that are exclusive to Nurus products helps your electronics match your furniture; allows transferring of information and video-conferences to be realized. Quick and accurate charging abilities coupled with multimedia features bring speed and ease into daily operations.

Design by Stefan Brodbeck

Stefan Brodbeck studied product design and architecture in Kassel. He started his professional life by working with Eichinger oder Knechtl architectures in Vienna. Brodbeck, who specialized in various fields ranging from home and office furnitures to industrial products, and from exhibition planning to design; founded his own design studio called Brodbeck Design in 1994.



DIMENSIONS (mm)

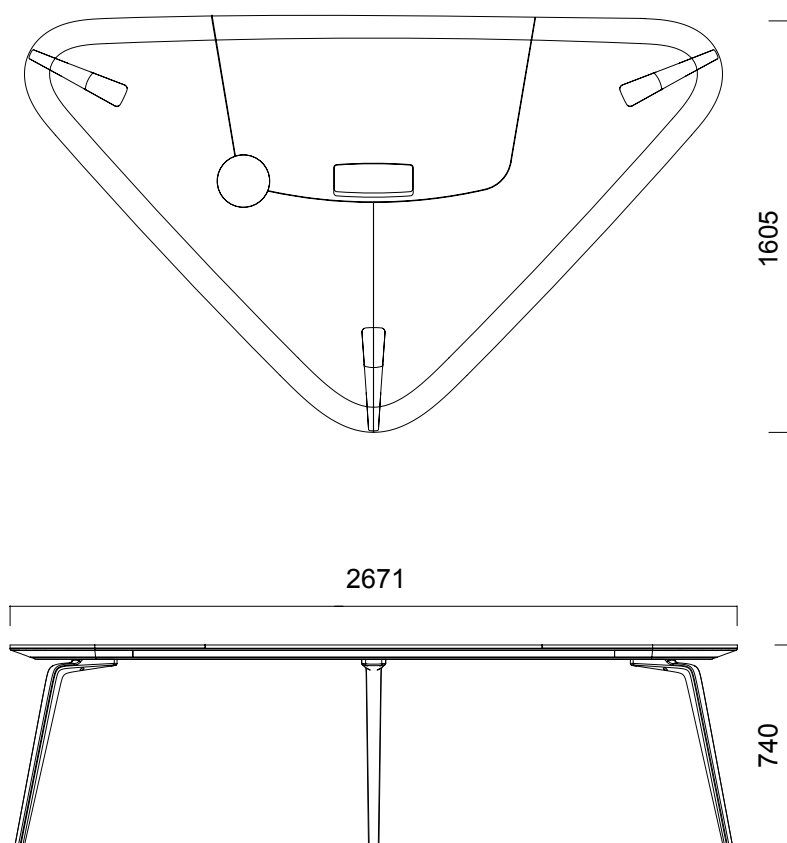

Dimensions defined in millimeters.

Materials

Tabletops have veneer and recomposed veneer options with or without desk pad. Desk pad is eco leather with 3 colors option. Legs are lacquered.*

*Please refer to technical document.

Notes

Wireless phone charging unit is optional for all versions.

Electrical cable cap option is available for Triangle Desk, Oval Desk w/ 2 legs and Asymmetric Desk w/ 2 legs.

For all cabinet options refer to the Ashbury Storage Units document.